

PIglide MB Miniature Linear Stage with Air Bearings

High Performance, Cleanroom Compatible, Customizable



A-141

- Size of the motion platform 57 mm × 93 mm
- Low profile 38 mm
- Travel ranges to 35 mm
- Load capacity to 3 kg
- Velocity to 0.25 m/sec
- Acceleration to 3.5 m/s²

Product Overview

The PIglide MB linear stage with air bearing is equipped with a servo linear motor drive with preloaded air bearings and integrated optical linear encoder. This stage offers ultra-precision in miniature format. The combination of the noncontact components results in a frictionless motion platform that offers the highest performance, quality, and lifetime.

Accessories and options

- PIglide filter and air preparation kits
- Single and multi-axis motion controller
- XY setups and individual configurations
- Counterbalance options for vertical (Z) orientations
- Base plates made of granite and systems for reducing vibration

Application fields

The stage is ideally suited for many high precision applications, such as metrology, photonics alignment, optics positioning, and scanning. The noncontact design also is ideal for cleanroom applications. Electrical cables are not moved. The air bearing module offers a locking design for the ultimate in position stability.

Specifications

Motion	A-141	Unit	Tolerance
Active axes	X		
Travel range	35	mm	
Pitch / yaw ⁽¹⁾ over the entire travel range	10	μrad	max.
Straightness / flatness ⁽¹⁾ over the entire travel range	0.5	μm	max.
Velocity ⁽²⁾ , unloaded	0.25	m/s	max.
Acceleration ⁽²⁾ , unloaded	3.5	m/s ²	max.

Mechanical properties	A-141	Unit	Tolerance
Load capacity in z ⁽³⁾	3	kg	max.
Moved mass	0.3	kg	
Overall mass	0.6	kg	
Guide type	Air bearing		

Drive properties	A-141	Unit	Tolerance
Drive type	Linear motor, ironless, 3-phase		
Intermediate circuit voltage, effective	48, nominal 80, max.	V DC	
Peak force	2.3	N	typ.
Nominal force	0.58	N	typ.
Force constant, effective	2.1	N/A	typ.
Resistance phase-phase	22.4	Ω	typ.
Inductivity phase-phase	1.0	mH	typ.
Back EMF phase-phase	0.7	V·s/m	max.
Cabling	Internal, no moving cable		

Positioning	A-141
Integrated sensor	Incremental linear encoder with travel range limits and home index
Sensor signal	Sin/cos, 1 V peak-peak, 20 μm signal period
Sensor resolution	1.2 nm ⁽⁴⁾
Bidirectional repeatability	±0.1 μm ⁽⁴⁾
Accuracy, uncompensated ⁽⁵⁾	±2.0 μm
Accuracy, with error compensation ⁽⁵⁾	±0.25 μm

Miscellaneous	A-141
Operating pressure ⁽⁶⁾	65±5 psi (450±35 kPa)
Air consumption	<1.0 SCFM (28 SLPM)
Air quality	Clean (unfiltered to 1.0 µm or better) – ISO 8573-1 class 1 Oil free – ISO 8573-1 class 1 Dry (-15 °C dew point) – ISO 8573-1 class 3
Materials	Hardcoat aluminum, stainless steel fasteners

(1) Dependent on the flatness of the surface, on which the stage is mounted.

(2) Can be limited by the payload, controller or drive.

(3) Assumes payload CG is centered no more than 50 mm above the motion platform. The stage is designed for horizontal operation only.

(4) Assumes 16384x interpolation. Contact PI for the use of other factors.

(5) Improved accuracy can be obtained with controller-based error compensation. The stage must be ordered with a controller from PI to reach these values.

Accuracy values assume short-term duration and do not consider the long-term effects of thermal drift on the stage.

(6) To protect the stage against damage, it is recommended to connect an air pressure sensor to the E-Stop input of the controller.

Drawings and Images

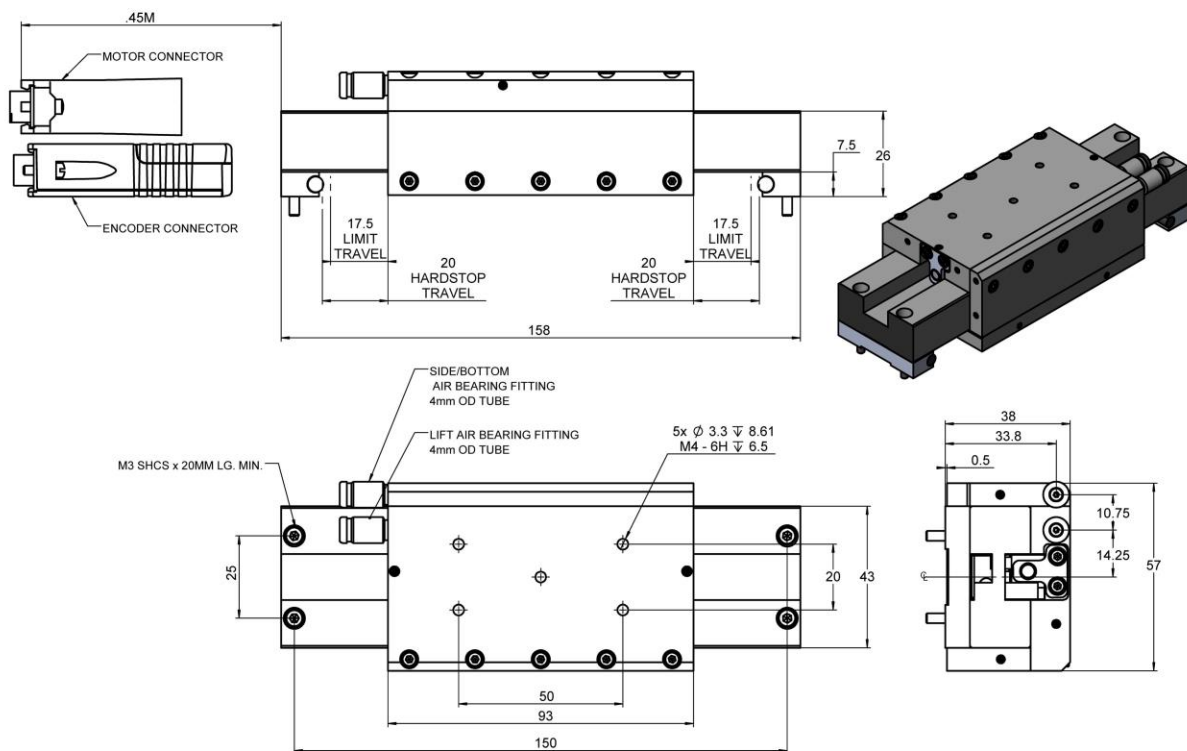

A-141.035A1, dimensions in mm

Ordering Information

A-141.035A1

PIglide MB miniature air bearing module, 35 mm travel range, linear encoder with sin/cos signal transmission, 20 µm signal period, 3-phase linear motor, 48 V

Alternative TTL encoder resolutions are available on request.